

- **Sign System: HED-200 Projection Mount**
 - (1) .125 Aluminum Panel: (H) 24" x (L) 24"
 - (2) U-Channel Lengths @ 26"
- **Paint:**
 - Standard White - Panel, U-Channels, Posts, Caps
- **Double Post Mount w/ Base Plates**
 - (2) Post Size: 2 1/4" x 2 1/4" x (L) 28" with Caps
 - (2) 1/4" Aluminum Base Plates: 8" x 8"

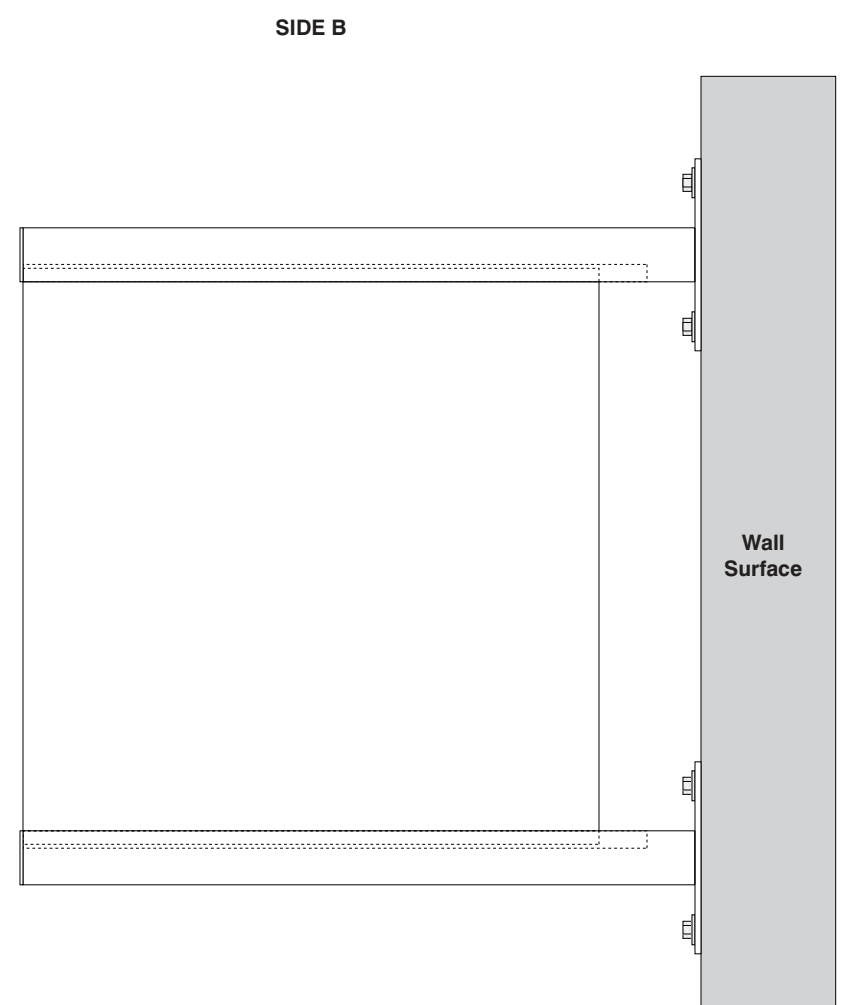

Date	DWG# HED-200_ProjectionMount	Scale:	1"=1'	Customer		Mounting	Double Post Projection Mount		Quote #	
XX.XX.XX						SF/DF	Double Face		Sales Rep.	
Quantity				Location		Illuminated	NO	UL	Illustrator:	
1						Voltage	N/A	Amp		
Page				System	HED-200 (24" x 24")	ADA	No	Rev. 0	Reviewed By:	
1 of 1				Projection Mount Sign System		*Due to the ADA/ANSI's wide interpretation and other factors that may exist, we cannot affirm compliance in all situations and is hereby removed from responsibility regarding these issues.				

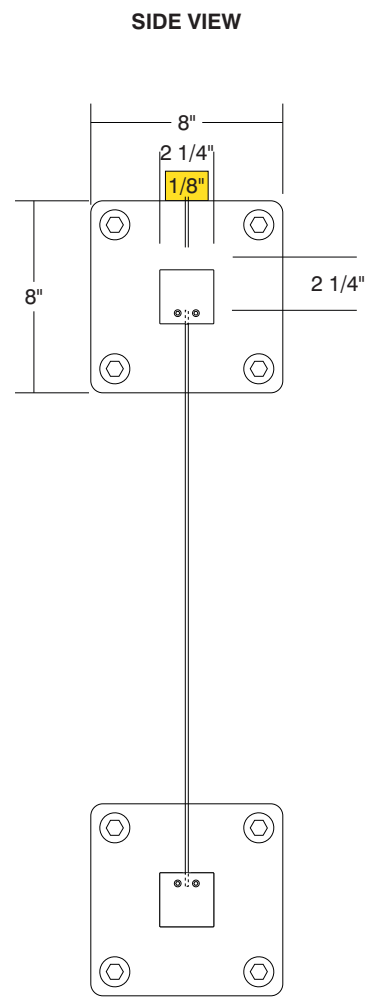

• 6400 Howard Drive, Fairview PA 16415 • Toll Free 800.458.0591 •
 • PA 814.833.7000 • Fax 814.838.0011 •
 www.howardindustries.com

All concepts and designs represented by this drawing are the property of Howard Industries and may not be reproduced or used in any manner without written consent. ©Copyright 2020 Howard Industries.