

**• Sign System: Perma-Banner (Wall Mount)**

- .125" Aluminum Panel: (H) 48" x (L) 26 1/4"
- (4) 1/2" Safety Radius Corners

**• No Paint:**

- Mill Finish - Panel
- Dove Grey - Mounting Extrusion

**• Perma Banner Bracket Extrusion (L) 48"**

- (3) 3" x 7" Evenly Distributed Aluminum Mounting Strips
  - (2) Located 6" O.C. in From Extrusions Ends
- (4) .391" Dia. Evenly Distributed Pre-Drilled Thru Holes
  - (2) 2" On Center in From Panel Ends

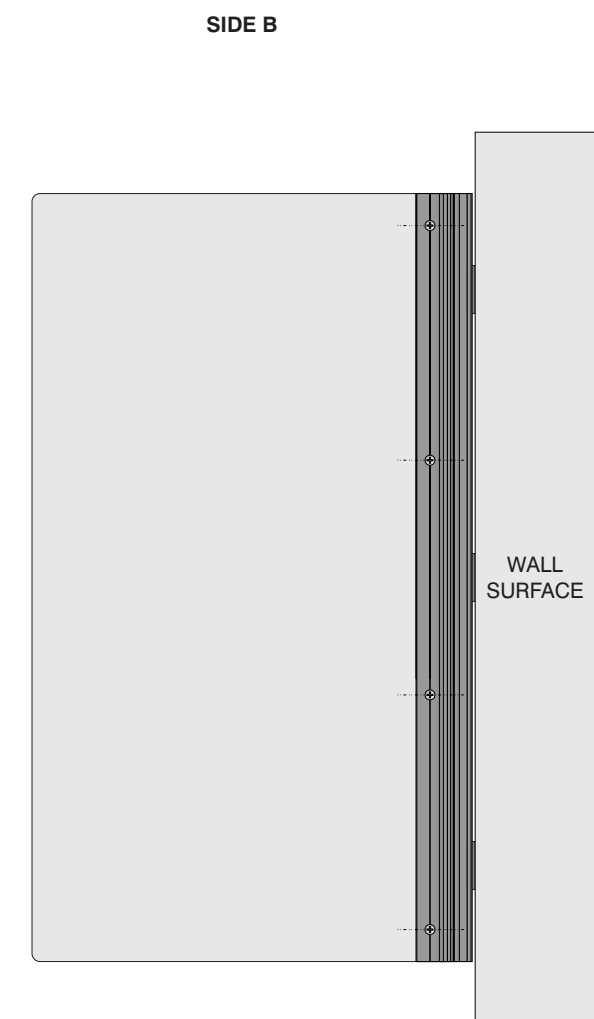
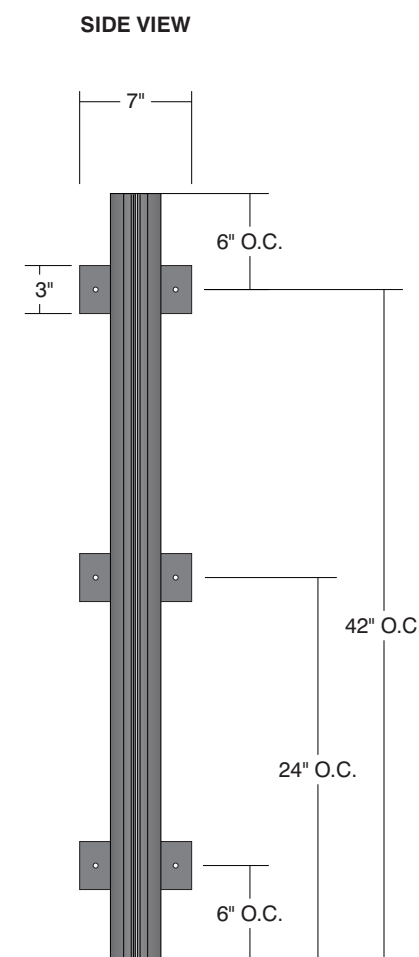

Date	DWG# Perma-Banner_Standard_WallMount	Scale:	1"=1'	Customer	Mounting SF/DF	Wall Mounted Double Face	Quote #
XX.XX.XX					NO	UL	Sales Rep.
Quantity				Location	Voltage	N/A Amp N/A	Illustrator:
1				System	ADA	No Rev. 0	Reviewed By:
Page				<b>Perma-Banner (48" x 24") Standard Wall Mount Sign System</b>	*Due to the ADA/ ANSI's wide interpretation and other factors that may exist, we cannot affirm compliance in all situations and is hereby removed from responsibility regarding these issues.		
1 of 1							



• 6400 Howard Drive, Fairview PA 16415 • Toll Free 800.458.0591 •  
• PA 814.833.7000 • Fax 814.838.0011 •  
www.howardindustries.com

All concepts and designs represented by this drawing are the property of Howard Industries and may not be reproduced or used in any manner without written consent. ©Copyright 2020 Howard Industries.