

**Custom HED-150 Changeable Panel Detail**

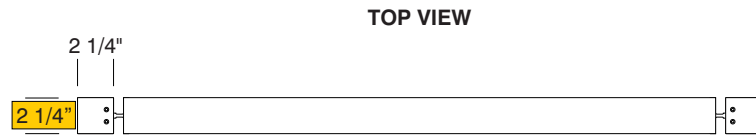

TOP VIEW

SIDE A

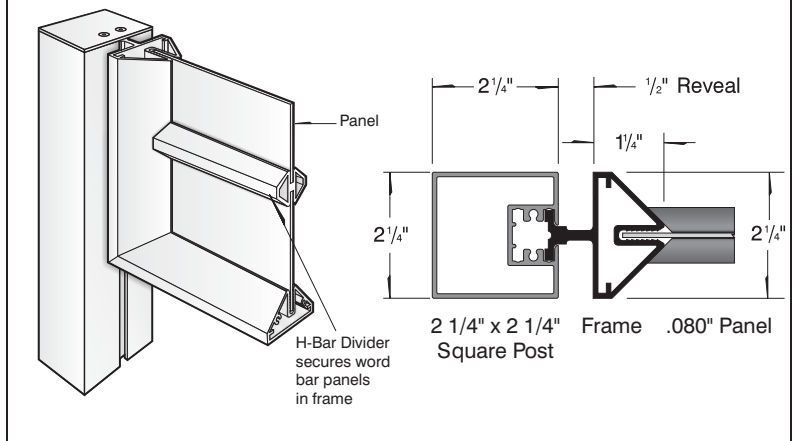
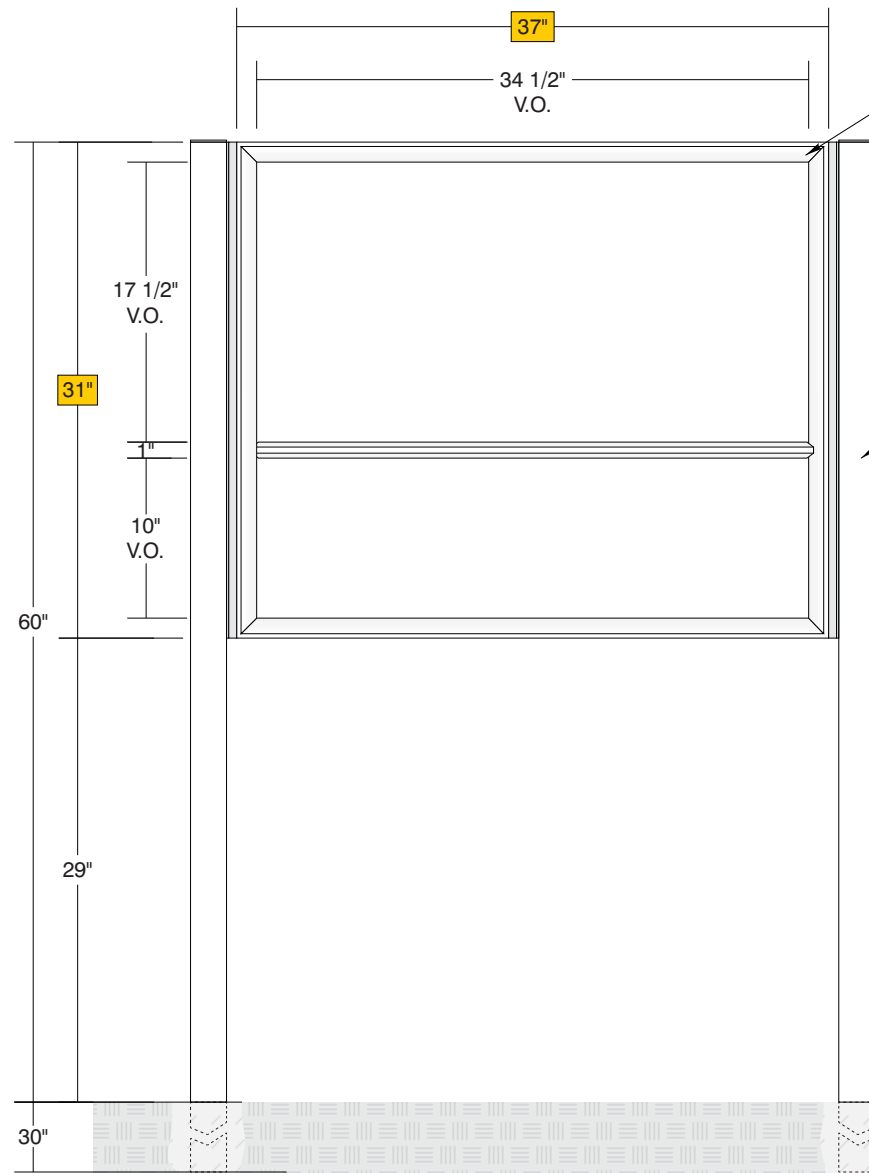

• **Sign System: HED-150 Changeable Panel**

- (1) .080" Top Aluminum Panel: (H) 18 5/8" x (L) 36"
- (1) .080" Bottom Aluminum Panel: (H) 11 1/8" x (L) 36"
- (1) H-Bar Divider: (H) 1" x (L) 35 1/8"

• **Paint:**

- Standard White - Frame, Panels, H-Bar, Post, Caps

• **Double Post Mount**

- (2) Post Size: 2 1/4" x 2 1/4" x (L) 90"with Caps

Represents  
6 ft.

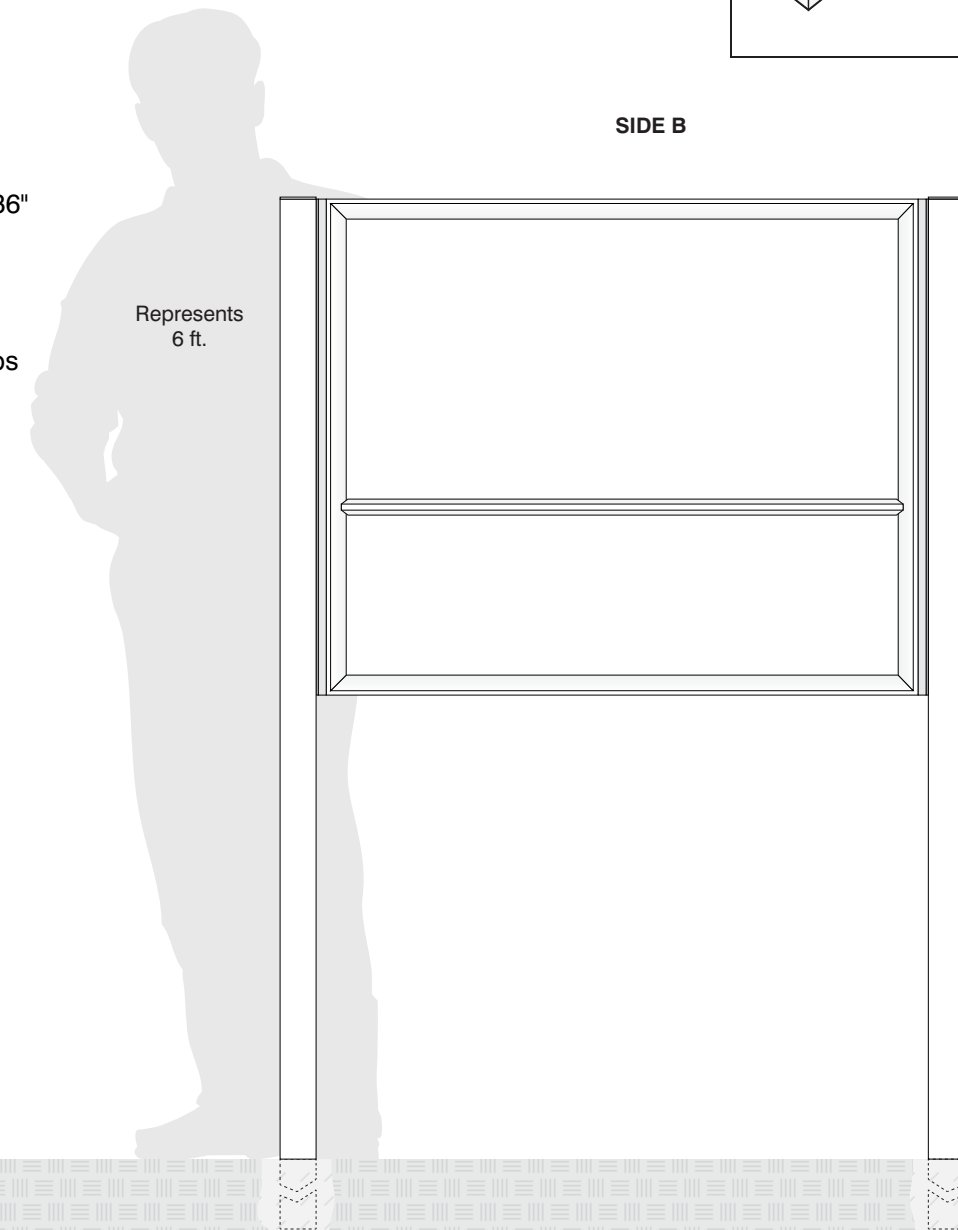

SIDE B

Date	DWG# HED-150_Changeablepanel	Scale:	1"=1'	Customer	Mounting SF/DF	Double Post Mount Double Face	Quote #
2.14.23				Location	ILLUMINATED	NO UL	Sales Rep.
Quantity				System	Voltage	N/A Amp N/A	Illustrator:
1				HED-150 30" x 36" Changeable Panel Sign System	ADA	No Rev. 0	Reviewed By:
Page					*Due to the ADA/ ANSI's wide interpretation and other factors that may exist, we cannot affirm compliance in all situations and is hereby removed from responsibility regarding these issues.		
1 of 1					 <p>• 6400 Howard Drive, Fairview PA 16415 • Toll Free 800.458.0591 • • PA 814.833.7000 • Fax 814.838.0011 • www.howardindustries.com</p> <p>All concepts and designs represented by this drawing are the property of Howard Industries and may not be reproduced or used in any manner without written consent. ©Copyright 2020 Howard Industries.</p>		