

Assembly and Installation Instructions

Carefully select the location of your sign to be sure that it will be readily visible to those for which it is intended. Before installing any sign, be sure that the installation does not obstruct traffic or hamper local utilities, landscape, maintenance, snow-plowing, etc...

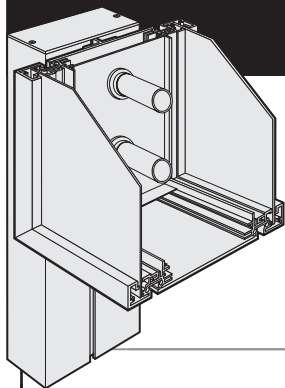

Double Post Mount

Step 1

Carefully unpack the posts and frame assembly from the shipping cartons. Laying the posts on the ground (use shipping cartons underneath to avoid damage), slide the frame assembly into the post slots from the bottom until the frame is flush to the post caps, which are attached prior to shipping. Slide the locking squares into the post slots flush to the bottom of the frame and tighten in position using an allen wrench.

Step 2

Laying the assembled sign on the ground as a guide, dig two 12" diameter x 30" deep holes; if the sign panel is 36" or higher, dig the holes 36" deep. Insert the sign posts into the holes and fill each hole with concrete. Level the sign both horizontally and vertically.

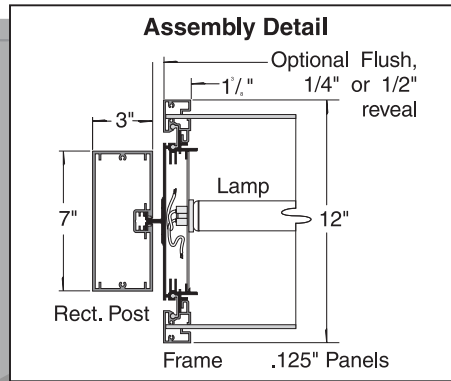
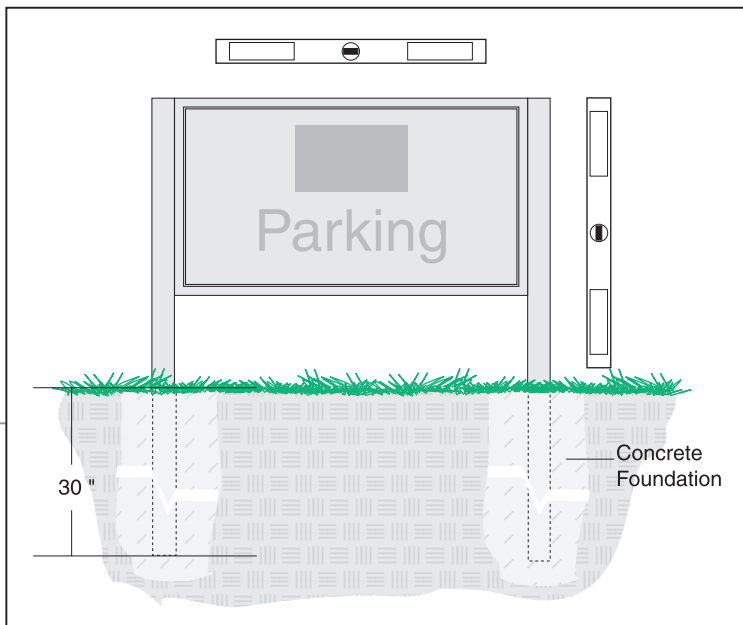

Note:
Assembly is the same when optional post styles are used.

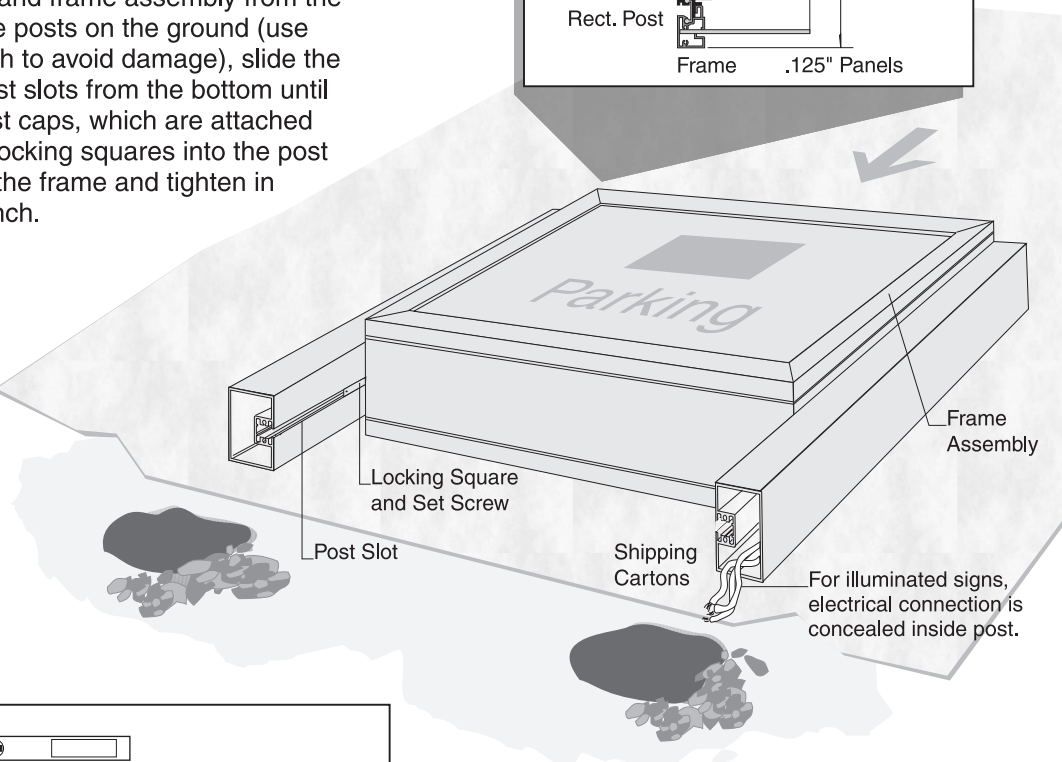

NOTE: If illuminated, make electrical connections as required per local codes.





Full Round Post and Post Covers

Step 1

Laying the posts on the ground (use shipping cartons underneath to avoid damage), remove the caps from the top of the posts and set them safely aside.

Step 2

Slide the frame assembly into the post slots from the top until the frame is flush with the radius post covers. Replace the post caps removed in Step 1 using the supplied fasteners, two per cap.

Step 3

With the sign laying on the ground as a guide (use shipping cartons underneath to avoid damage), dig two 20" diameter holes. The holes must be deep enough to totally bury the mounting posts and about 12 inches of the radius post covers. Correct installation will conceal the post covers with about 12 inches of top soil or other landscape material. Level the sign both horizontally and vertically.

