

**• Sign System: Perma-Banner**

- .125" Aluminum Panel: (H) 48" x (L) 26 1/4"
- (4) 1/2" Safety Radius Corners

**• No Paint:**

- Mill Finish - Panel
- Duranodic Bronze - Mounting Extrusion

**• Perma Banner Bracket Extrusion (L) 48"**

- (4) 5/8" x 3/16" Evenly Distributed Pre-Routed Mounting Slots
  - (2) Located 6" O.C. in From Extrusions Ends
- (4) .391" Dia. Evenly Distributed Pre-Drilled Thru Holes
  - (2) 2" On Center in From Panel Ends

SIDE B

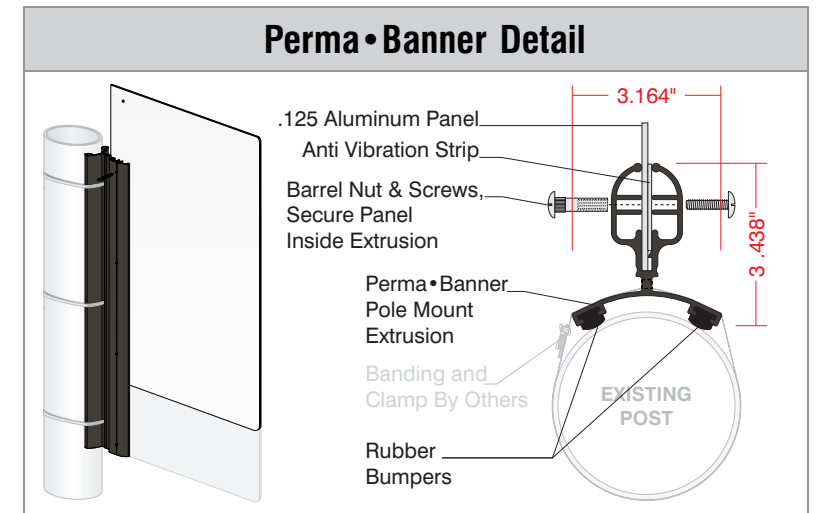

Date	DWG# Perma-Banner_Standard	Scale:	1"=1'	Customer	Mounting SF/DF	Pole Mount Double Face	Quote #	
XX.XX.XX				Location	Illuminated	NO	Sales Rep.	
Quantity				System	Voltage	UL Amp N/A	Illustrator:	
1				Perma-Banner (48" x 24") Standard Sign System	ADA	No Rev. 0	Reviewed By:	
Page					*Due to the ADA/ANSI's wide interpretation and other factors that may exist, we cannot affirm compliance in all situations and is hereby removed from responsibility regarding these issues.			
1 of 1								



• 6400 Howard Drive, Fairview PA 16415 • Toll Free 800.458.0591 •  
 • PA 814.833.7000 • Fax 814.838.0011 •  
 www.howardindustries.com

All concepts and designs represented by this drawing are the property of Howard Industries and may not be reproduced or used in any manner without written consent. ©Copyright 2020 Howard Industries.